

Secondary Handrail IRC Vinyl & Aluminum System

- If you are using a power saw to cut the Rail and Aluminum Stiffener, we recommend a carbide tipped blade with at least 60 teeth.
- Use a two-part adhesive designed for bonding aluminum, and follow the manufacturers recommended procedures.
- A Hand Rail Bracket or Wall Return is required every 72". Check with the local building authority, as requirements vary between jurisdictions.

WARNING: Always wear safety goggles and other protective gear as required.

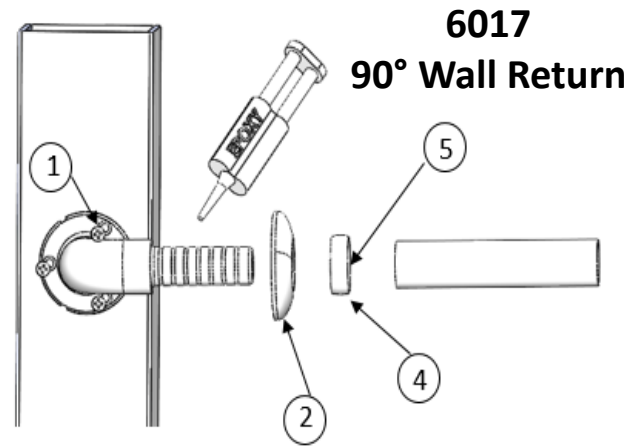

6017 90° Wall Return

1) Attach the 6017, 90° Wall Return to the mounting surface using the #10 x 2" screws provided. 2) Slide the supplied Wall Return Cover Plate (Part # 6011) onto the Wall Return, rotate and snap it into position. 3) Using a twisting motion, slide a 6" Straight Joiner (sold separately - Part # 6007), into the Wall Return. 4) Slide a Joint Ring (sold separately - Part # 6009), onto the end of the Rail (6000). 5) Apply the two-part epoxy into the end of the Rail and insert the 6017 Wall Return With Joiner into the Rail. Let the epoxy cure per the manufacturer's instructions.

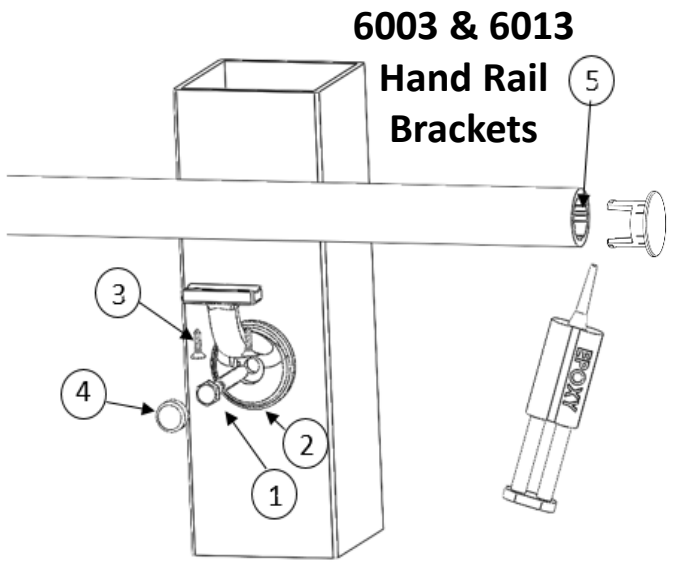

6003 & 6013 Hand Rail Brackets

1) For the 6003 Hand Rail Bracket, drill a pilot hole with a 1/4" drill bit and mount it using a 3/8" x 2" (minimum) stainless steel lag bolt - not supplied. For the 6013 Inside Corner Bracket, use the two supplied #12 x 1" screws. 2) Place the 6000 Rail on the bracket in the appropriate position. 3) Pre-drill two holes in the Rail using a 3/16" drill bit for either the 6003 Bracket, or the 6013 Bracket. Attach the Rail to the Bracket using the 1" screws provided and a #2 Philips head screwdriver. 4) Conceal the lag bolt or screws with the Hole Plug(s) provided. 5) If either end is a termination point - apply a two-part aluminum epoxy to the inside of the 6000 Rail and insert a Rail End Cap (sold separately - Part # 6028). Let the epoxy cure as per the manufacturer's instructions.

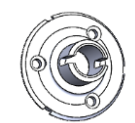

6002
Straight Wall Return
(KIT)



6017
90° Wall Return with
Joiner (Kit)



6003
Hand Rail Bracket (KIT)



6007
4 Pack 6" Straight
Joiner



6008
Internal Adjustable
Joiner

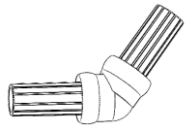

6018
External Adjustable
Joiner

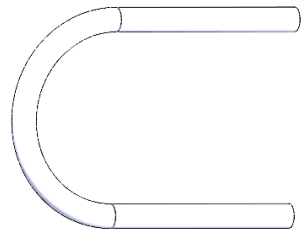

6005
End Loop

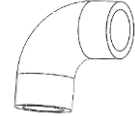

6004
90° Corner



6016
90° Corner with Joiner

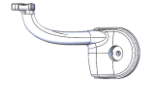

6013
90° Inside Corner
Bracket (KIT)



6009
4 Pack Joint Ring



6000
104" Rail and Aluminum
Stiffener



6028 Solid Rail
End Cap

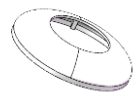

6011 4 Pack Wall
Return Cover Plate



6006 180° Post
Return

**Kits Include Necessary
Screws and Covers**

6007 6" Straight Joiner

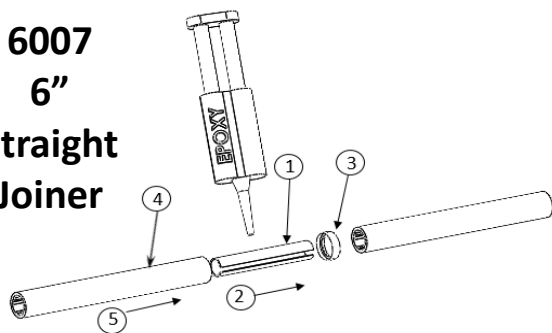

1) To join two pieces of 6000 Rail together, apply a two-part aluminum epoxy to the aluminum stiffener inside one of the Rails. 2) Using a twisting motion, insert a Straight Joiner - 6007, half way inside the Rail. 3) Attach a Joint Ring (sold separately - Part # 6009) over the Joiner and onto the Rail. 4) Apply epoxy to the aluminum stiffener inside the other Rail. 5) Using a twisting motion, slide the Joiner into the Rail until the ends of the two rails meet. Let the epoxy cure as per the manufacturer's instructions.

6006 180° Post Return

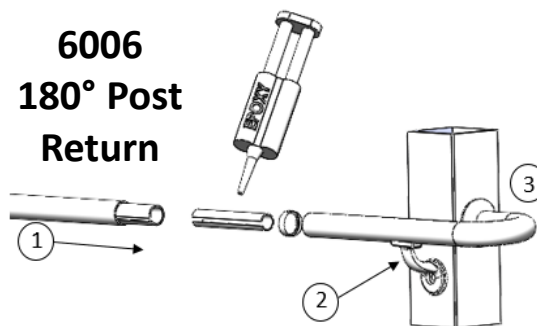

Cut the rail and post returns at desired location. 1) For level installation, refer to "6007 - Straight Joiner", for angled installation refer to "6008 & 6018 - Adjustable Corners". 2) Install bracket as described in "6003 - Hand Rail Bracket" instructions. 3) Refer to "6002 - Straight Wall Return" to attach end of post return to post face.

6004 & 6016 90° Corners

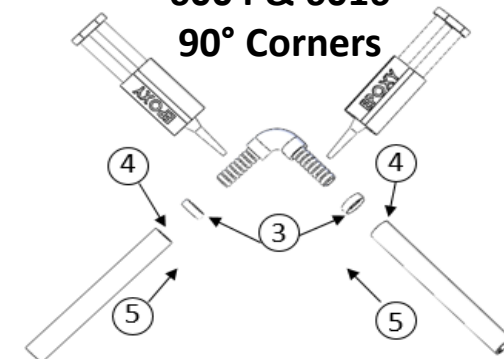

1) For 6004 only: apply a two-part aluminum epoxy inside the 90° Corner openings. 2) Using a twisting motion, insert a 6" Straight Joiner (sold separately - Part # 6007) into each Corner opening. 3) For both 6004 & 6016: Slide a Joint Ring (sold separately - Part # 6009) over the Joiners and onto each end of the 90° Corner. 4) Apply the two-part epoxy to the inside of the 6000 Rails. 5) With a twisting motion, slide the Rails all the way onto the Joiners. Let the epoxy cure as per the manufacturer's instructions.

6002 Straight Wall Return

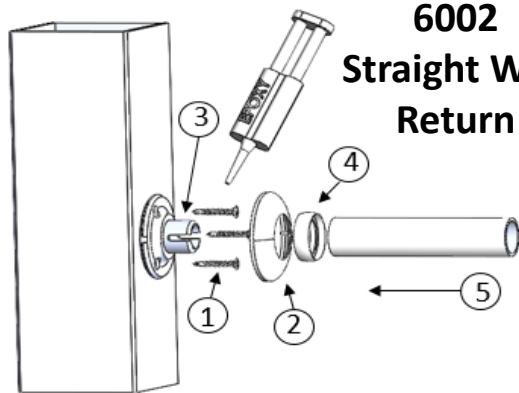

1) Attach the 6002 Straight Wall Return to the mounting surface using the three #10 x 2" screws provided. 2) Slide the supplied Wall Return Cover Plate (6001) onto the Wall Return - rotate and snap it into position. 3) Apply a two-part epoxy to the end of the Wall Return. 4) Slide a Joint Ring (sold separately - Part # 6009), onto the end of the Rail (6000). 5) Using a twisting motion, slide the Rail onto the Wall Return. Let the epoxy cure as per the manufacturer's instructions.

6008 & 6018 Adjustable Corners

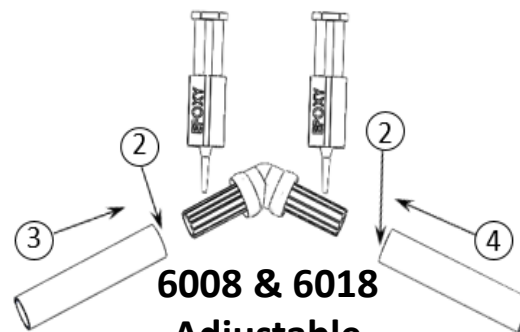

1) For the 6008 Joiner only, cut the ends of the 6000 Rails at the desired angle. Check the assembly before gluing together. 2) For both 6008 & 6018: Apply a two-part aluminum epoxy inside the cut end of the Rails. 3) Using a twisting motion, insert one end of the Rail into the Joiner. 4) Repeat for the other Rail into the other end of the Joiner. Let the epoxy cure as per the manufacturer's instructions.

6005 End Loop

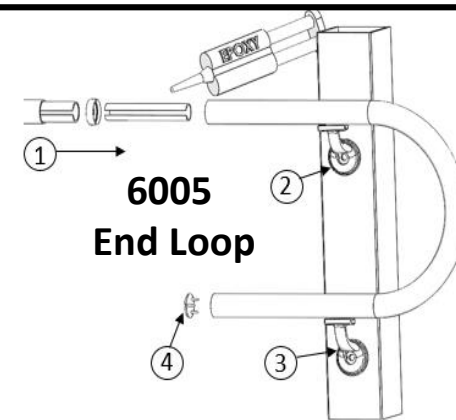

Cut the rail and end loop at desired location. 1) For level installation, refer to "6007 6" Straight Joiner", for angles installation refer to "6008 & 6018 Adjustable Corners". 2) Install top bracket as described in "6003 - Hand Rail Bracket". 3) Repeat for the bottom bracket. 4) Using a two-part metal epoxy, attach hand rail end cap (sold separately - Part #6028) to unfinished end of loop.